

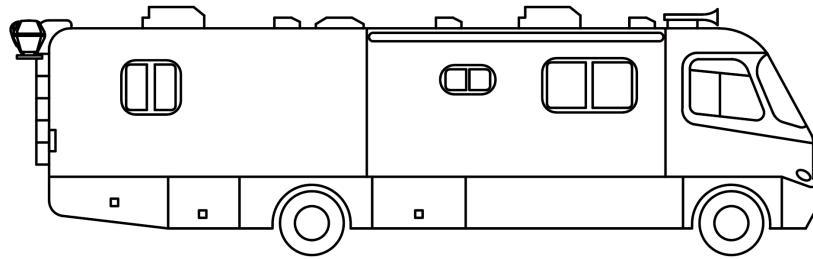

MB400 Ladder Mount Bracket

Installation Instructions



Note: Please read thru the entire installation procedure before beginning. Questions? (800) 982-9920

The MB400 Ladder Mount Bracket allows semi-permanent installation of VuQube models VQ2000 and VQ3000 on the rear ladder of your RV (**Fig. 1**).

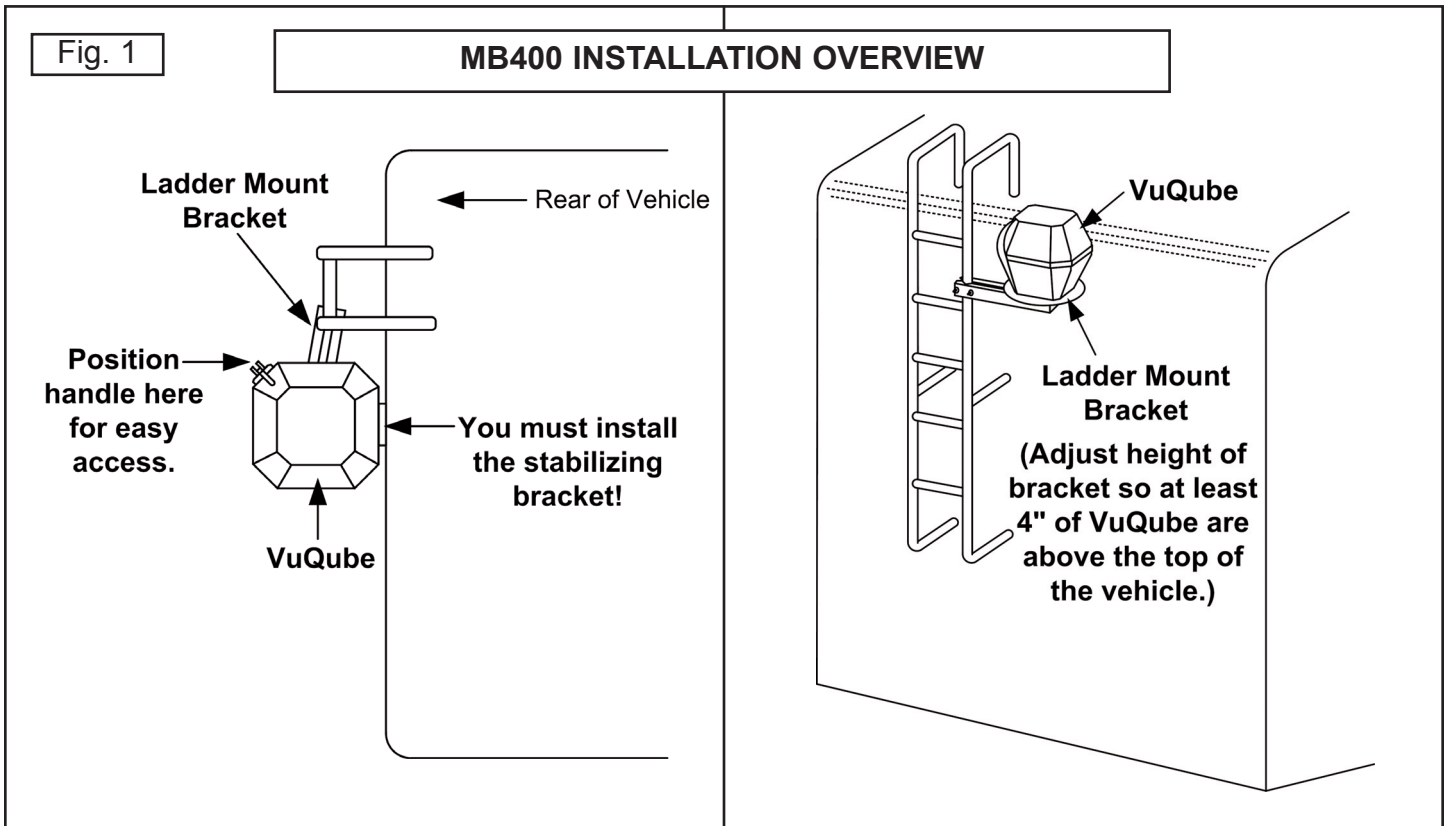

LADDER MOUNT BRACKET INSTALLATION

1. Determine the desired height and location of the VuQube. Keep in mind the following:
 - a) The VuQube is a directional antenna and requires an unobstructed view to the southern sky. Be sure at least 4" of the VuQube enclosure are above the roof of the vehicle so that adequate signal can be received by the antenna. When installing the bracket, adjust the height of the arms on the ladder to assure the top of the VuQube is positioned a minimum of 4" above the roof.
 - b) The VuQube requires a 16" wide space to be mounted.
2. Attach the ladder mount bracket to the ladder so that the VuQube sits in the desired location. Tighten all hardware securely (**Fig. 2**). Keep in mind the following:
 - a) The stabilizing bracket adheres to the back of the vehicle and fastens to one of the square holes in the lower platform. Make sure one of the square holes faces the back of the vehicle.
 - b) When the locking holes align, they should face toward the ladder for easy access. A locking bolt (included) or other locking device such as a padlock **MUST** be inserted through the holes to prevent the upper platform from rotating and accidentally releasing the VuQube.
 - c) You can change the angle of the clamping arms on the ladder and rotate the upper/lower platform assembly to position the VuQube close to the back of the vehicle.

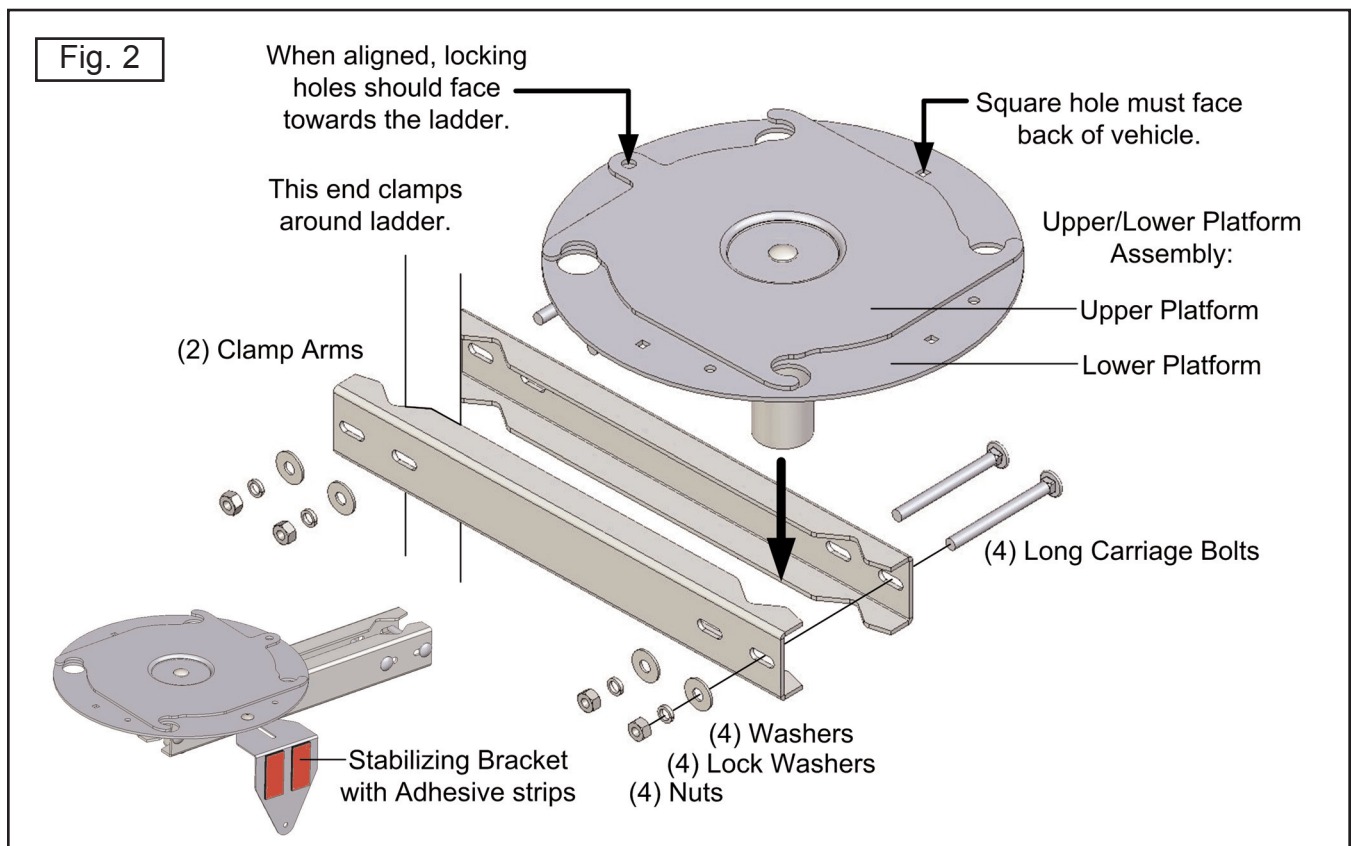

IMPORTANT! An adhesive backed bracket is included to stabilize the VuQube. **THIS BRACKET MUST BE ATTACHED TO THE VEHICLE USING THE ADHESIVE STRIPS ON THE BRACKET.** Failure to attach this bracket will void the VuQube warranty.

The area where the adhesive will adhere to the vehicle must be flat, free of contaminants and have the paint tightly adhered.

The temperature must be above 65° for the adhesive to adhere properly.

3. **TEMPORARILY** place the VuQube in position on the platform (rubber feet on VuQube will sit in matching holes in platform). Verify VuQube is at correct height and stabilizing bracket will reach back of vehicle. (Stabilizing bracket will slide along slot to reach back of vehicle.) Remove VuQube from platform.

If not at correct height, **REMOVE VUQUBE FROM PLATFORM FIRST**, then adjust platform as necessary. Repeat step 3 as necessary.

4. Use alcohol to thoroughly clean the area where the adhesive on the bracket will contact the vehicle.
5. Fasten the stabilizing bracket to the platform with the short carriage bolt, washer and nut. **DO NOT TIGHTEN COMPLETELY. BRACKET SHOULD SLIDE BACK AND FORTH ALONG SLOT (Fig. 3).**

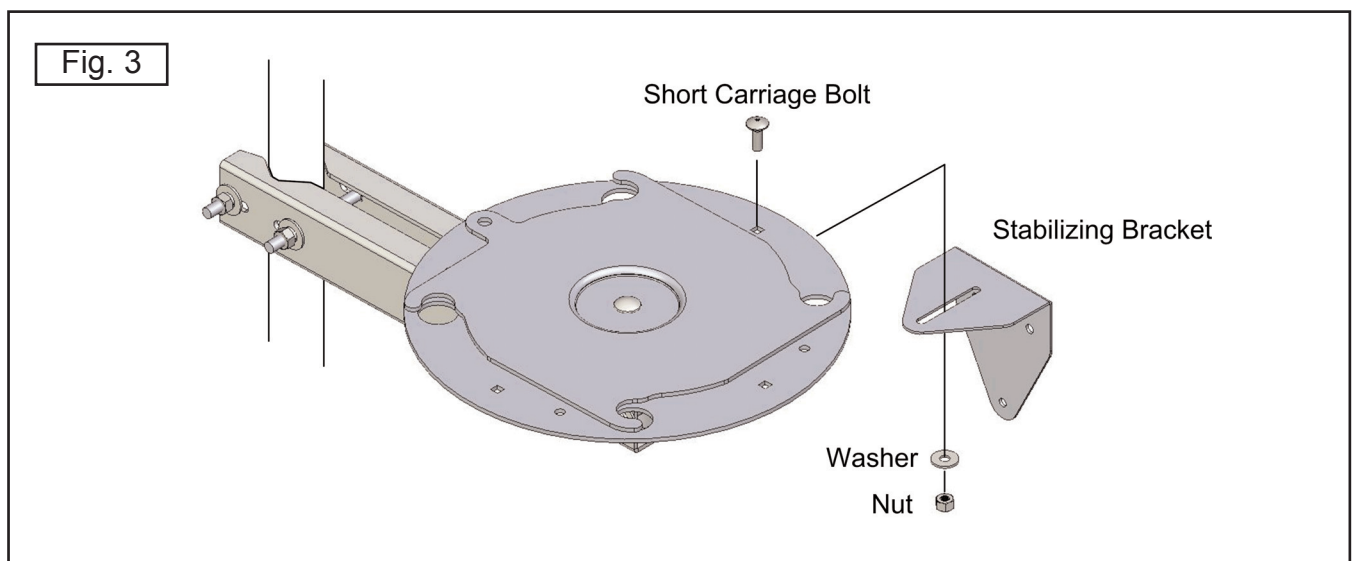

6. Remove the protective tape from adhesive strips on bracket and press the bracket firmly onto the vehicle.
7. Tighten nut.
8. Allow adhesive to dry 20 minutes.

Continued on back

USING THE QUICK RELEASE FEATURE OF THE MB400

IMPORTANT! You **MUST** install the supplied locking bolt, or other locking device such as a padlock through the alignment holes in the upper and lower platforms to prevent the VuQube from accidentally coming off the platform.

To attach the VuQube to the ladder mount bracket:

Set the VuQube into the holes in the lower platform (Position handle toward the ladder for easy access.) Rotate the upper platform counterclockwise and install the locking device.
YOU MUST INSTALL THE LOCKING DEVICE!

To remove the VuQube from the ladder mount bracket:

Remove the locking device, rotate the upper platform clockwise, and remove the VuQube.